

DC DA TYPE SUSPENSION HOIST

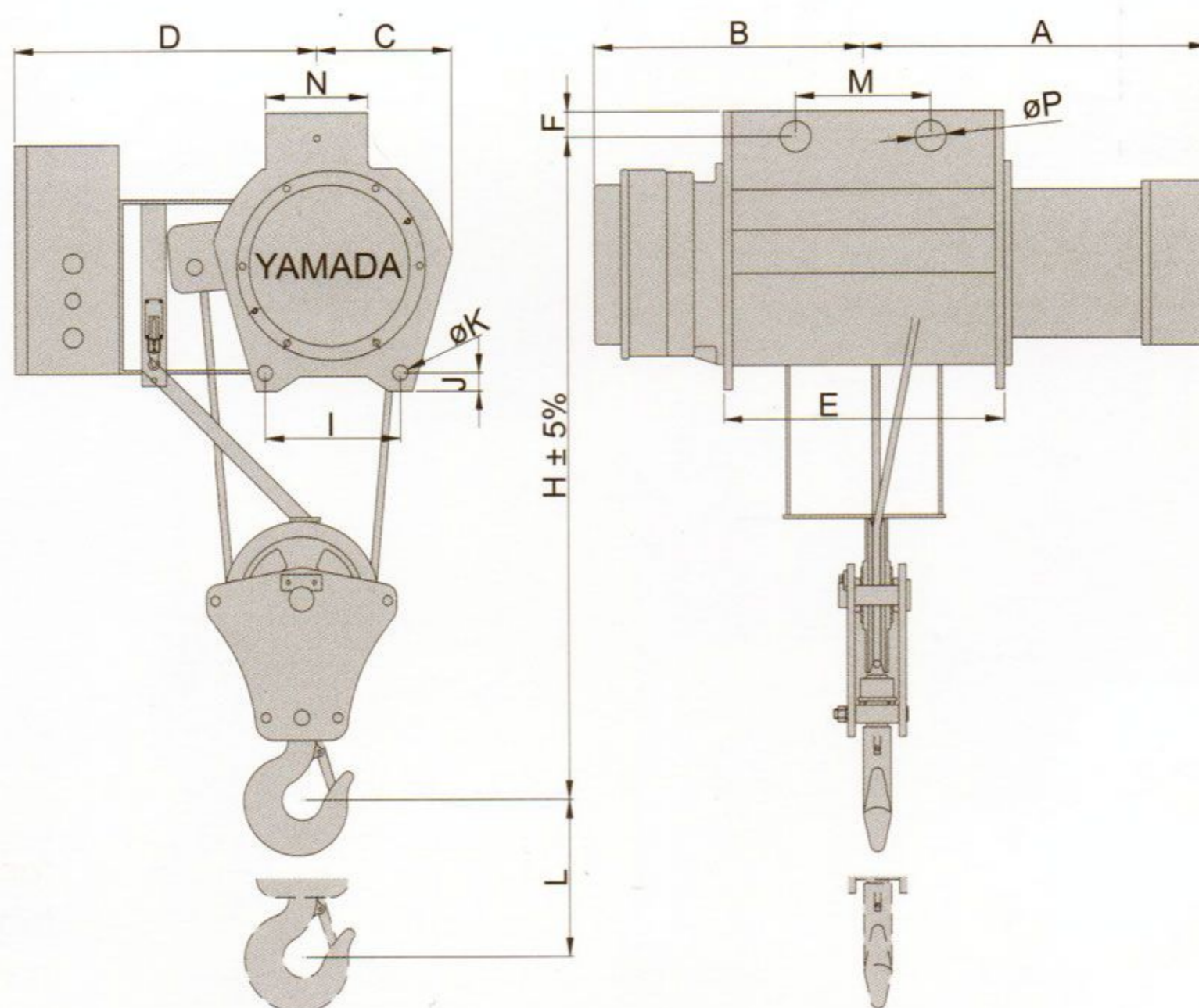

Hoisting	CAPACITY		0.5	1	2	3	5	7.5	10	15													
	M/min	50Hz	8.3	6.0	5.6	5.4	5.4	4.2	4.8	4.3													
		60Hz	10.0	7.2	6.8	6.5	6.5	5.2	5.8	5.2													
	Kw	50Hz	1.5	1.5	3.7	5.5	7.5	7.5	11	15	18.5												
60Hz																							
Wire rope	Diameter		Ø8		Ø10&Ø8	Ø10	Ø12	Ø14	Ø16	Ø20													
	Structure		6X37																				
	Nos		2		2&4	4																	
CAP	TYPE	Approximate Dimension (mm)																					
		L(M)	A	B	C	D	E	I	J	K	F	H	M	P	N	Kg							
0.5T	DCN-005	6	400	325	145	410	256					25	800	140	23	106	110						
		9	455	380			360										120						
		12	505	430			461										130						
1T	DCN-010	6	400	335	145	410	256					25	800	140	23	106	110						
		9	455	385			360										120						
		12	505	435			461										130						
2T	DCN-020	6	535	350	195	420	345	160	25	16	33	940	220	26	157	165							
		9	570	380			405									195							
		12	620	435			512									225							
	DAN-020	6	560	435			512					900	390										220
		9	630	510			662																245
		12	710	590			812																265
3T	DAN-030	6	705	485	235	510	556	210	25	17	40	1080	380	33	165	350							
		9	805	585			756									390							
		12	900	690			956									420							
5T	DAN-050	6	790	555	255	475	625	260	30	25	45	1180	450	40	222	540							
		9	900	665			850									565							
		12	1015	765			1063									655							
7.5T	DAN-075	6	975	720	325	565	776	330	25	26	60	1440	600	45	222	1040							
		9	1025	770			876									1170							
		12	1075	820			976									1280							
10T	DAN-100	6	1010	750	325	550	758	330	35	26	75	1525	600	52	222	1060							
		9	1110	850			958									1140							
		12	1190	930			1118									1230							
15T	DAN-150	6	990	780	375	600	785	360	40	26	80	1765	600	80	262	1510							
		9	1090	880			985									1710							
		12	1190	980			1185									1910							