

MAZ TYPE (UP DOWN DUAL SPEED 10:1)

MAIN & AUX HOISTS DOUBLE-RAIL WITH MOTOR-DRIVEN TROLLEY

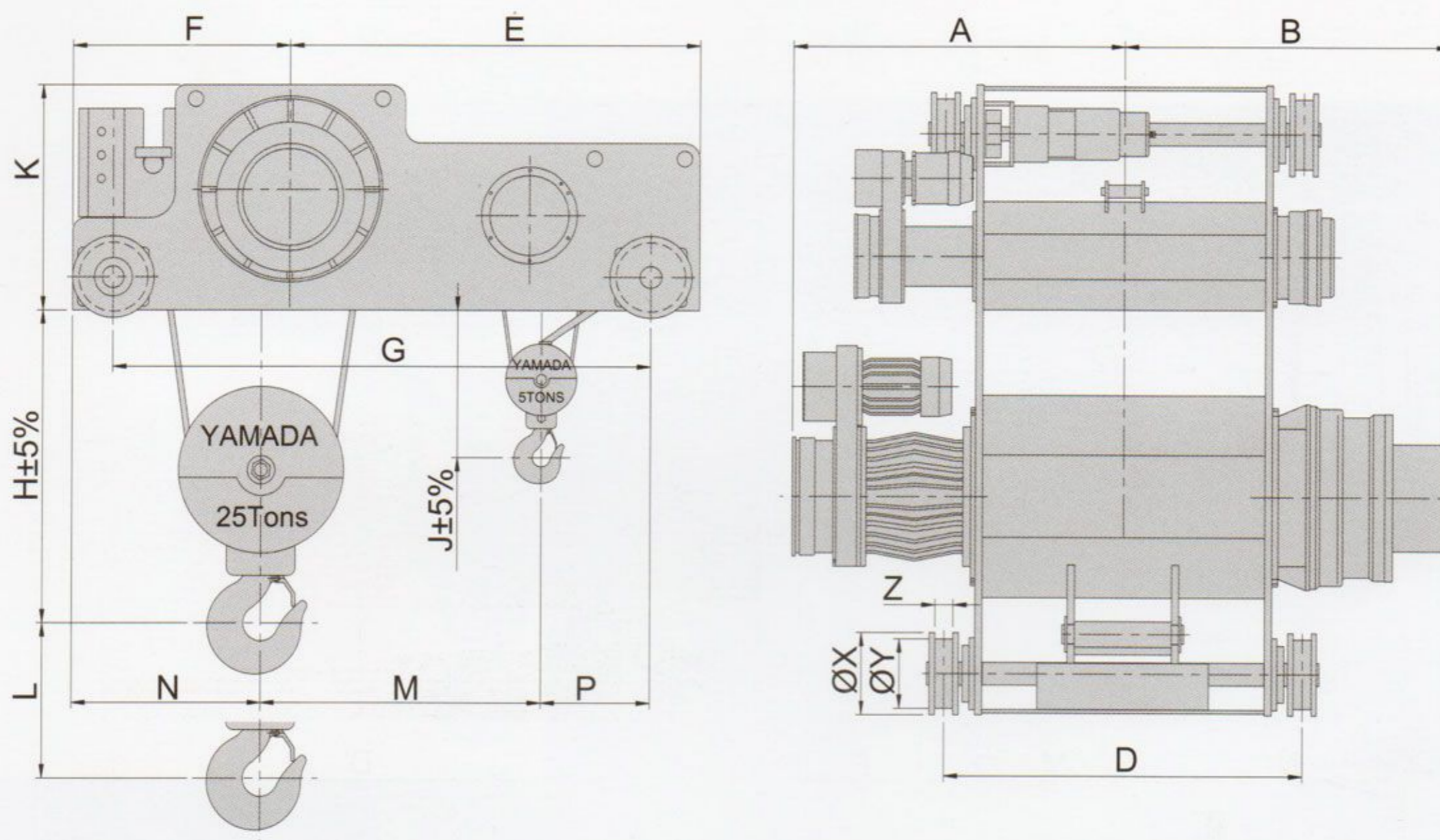

Hoisting	CAPACITY		7.5/3		10/3		15/5		20/5		30/5		30/10					
	M/min	50Hz	4.2~0.4	5.4~0.5	4.8~0.4	5.4~0.5	4.3~0.4	5.4~0.5	4.0~0.4	5.4~0.5	2.5~0.2	5.4~0.5	2.5~0.2	4.8~0.4				
	60Hz	5.2~0.5	6.5~0.6	5.8~0.5	6.5~0.6	5.2~0.5	6.5~0.6	4.8~0.4	6.5~0.6	3.0~0.3	6.5~0.6	3.0~0.3	5.8~0.5					
Kw	50Hz	7.5&0.75	5.5&0.75	11&2.2	5.5&0.75	15&1.5	7.5&0.75	18.5&2.2	7.5&0.75	22&2.2	18.5&2.2	7.5&0.75	22&2.2					
	60Hz	11&1.5	0.75	15&2.2	0.75	18.5&2.2	0.75	22&2.2	0.75	22&2.2	0.75	22&2.2						
Travel	M/min	50Hz	13		13		13		12		12		12					
		60Hz	16		16		16		15		15		15					
	Kw	50Hz	0.75		1.1		1.1		1.5		2.2		2.2					
		60Hz																
Wire rope	Diameter		Ø14	Ø10	Ø16	Ø10	Ø20	Ø12	Ø22.4	Ø12	Ø18	Ø12	Ø18	Ø16				
	Structure		6X37								6x37		6x37		6x37			
	Nos		4								8		4		8			
CAP	TYPE	Approximate Dimension (mm)																
		L(M)	A	B	D	E	F	G	K	H	J	N	M	P	X	Y	Z	Kg
7.5/3 T	MAN-7.5/3	6	980	715	950	1079	570	1420	495	825	630	505	670	474	200	170	60	1530
		9	1025	765	1050													1640
		12	1075	815	1150													1730
10/3 T	MAN-10/3	6	1010	750	950	1020	605	1380	540	885	630	481	670	474	220	180	60	1830
		9	1110	850	1150													1950
		12	1190	930	1300													2060
15/5 T	MAN-15/5	6	995	780	1000	1357	635	1690	640	1110	710	540	925	527	250	210	60	2710
		9	1095	880	1200													2840
		12	1195	980	1400													2970
20/5 T	MAN-20/5	9	1255	880	1200	1451	750	1850	725	1230	710	674	1000	527	290	250	60	3490
		12	1355	980	1400													3660
30/5 T	MAN-30/5	9	1400	1340	1600	1563	930	2100	880	1235	710	866	1100	527	350	300	60	4910
		12	1500	1440	1800													5160
30/10 T	MAN-30/10	9	1400	1340	1600	1905	930	2440	880	1235	885	866	1300	669	350	300	70	5540
		12	1500	1440	1800													5810